

Ordering Information

Model	CPU	Serial	Ethernet	Mini PCIe Socket	TPM	Micro SD Socket	Operating Temp.
UC-8112-LX	1 GHz	2	2	√	√	√	-10 to 60°C
UC-8162-LX	600 Mhz	2	2	√	-	-	-10 to 60°C
UC-8132-LX	300 Mhz	2	2	√	-	-	-10 to 60°C
UC-8131-LX	300 Mhz	1	2	-	-	-	-10 to 60°C

Your Trusted Partner in Automation

Moxa is a leading provider of industrial networking, computing, and automation solutions for enabling the Industrial Internet of Things. With over 25 years of industry experience, Moxa has connected more than 30 million devices worldwide and has a distribution and service network that reaches customers in more than 70 countries. Moxa delivers lasting business value by empowering industry with reliable networks and sincere service for industrial communications infrastructures.

Moxa Sales and Marketing Headquarters

Moxa Corporate Plaza
601 Valencia Ave., Suite 200
Brea, CA 92823, U.S.A.
Toll Free: 1-888-669-2872
Tel: +1-714-528-6777
Fax: +1-714-528-6778
usa@moxa.com

Moxa Design and Engineering Headquarters

Fl. 4, No. 135, Lane 235, Baoqiao Rd.
Xindian Dist., New Taipei City,
Taiwan, R.O.C.
Tel: +886-2-8919-1230
Fax: +886-2-8919-1231

The Americas Moxa Americas

Toll Free: 1-888-MOXA-USA
Tel: +1-714-528-6777
Fax: +1-714-528-6778
usa@moxa.com

Moxa Brazil

Tel: +55-11-2495-3555
Fax: +55-11-2495-6555
brazil@moxa.com

Europe

Moxa Germany

Tel: +49-89-3700-399-0
Fax: +49-89-3700-399-99
europe@moxa.com

Moxa France

Tel: +33-1-30-85-41-80
Fax: +33-1-30-47-35-91
france@moxa.com

Moxa UK

Tel: +44-1844-353-601
Fax: +44-1844-353-553
uk@moxa.com

Asia-Pacific

Moxa Asia-Pacific and Taiwan

Tel: +886-2-8919-1230
Fax: +886-2-8919-1231
asia@moxa.com
japan@moxa.com
taiwan@moxa.com

Moxa India

Tel: +91-80-4172-9088
Fax: +91-80-4132-1045
india@moxa.com

Moxa Russia

Tel: +7-495-287-0929
Fax: +7-495-269-0929
russia@moxa.com

Moxa Korea

Tel: +82-31-625-4048
Fax: +82-31-609-7996
korea@moxa.com

China

Moxa Shanghai

Tel: +86-21-5258-9955
Fax: +86-21-5258-5505
china@moxa.com

Moxa Beijing

Tel: +86-10-5976-6123/24/25/26
Fax: +86-10-5976-6122
china@moxa.com

Moxa Shenzhen

Tel: +86-755-8368-4084/94
Fax: +86-755-8368-4148
china@moxa.com

Small Size, Big Possibilities

RISC computer for versatile
wireless communications

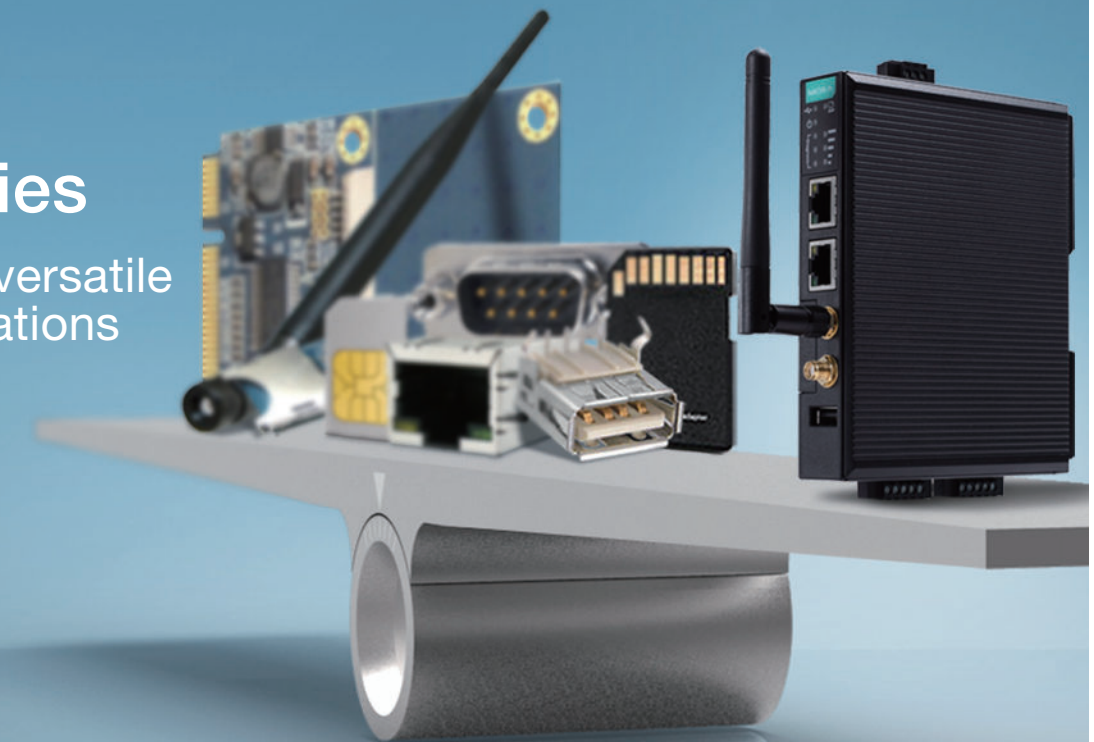

UC-8100 Wireless Computer

Small and Scalable: Unbeatable flexibility for managing heavy-load data processing and communications. Built-in SD, mini SD, and PCIe sockets allow a variety of expansion possibilities, including cellular and Wi-Fi modules for wireless connectivity.

Easier Management: Programmable Debian computers natively support standard Modbus devices, making it easy to link a variety of sensors to a remote SCADA system.

Stronger Security: Trusted Platform Module (TPM) encryption hardware and Moxa's patented Secure Boot protects your data.

See What Industrial Automation Experts Have to Say

Quick Facts

Expert Reviewer: Mustafa Güler

Application: Remote Connection to System Integration Lab

Location: Turkey

Product Review Q&A

Q: Why did you choose a UC-8100 RISC computer?

- A:**
- Well-known vendor
 - Connection capabilities (Ethernet, USB, serial)
 - Documentation
 - Debian distribution
 - ARM CPU

Q: For what application did you use the UC-8100 series RISC computer?

A: In our application, the Moxa UC-8100 is used to remotely connect to a prototype located at our system integration laboratory which is located far away from our offices. Test engineers make their controls on the prototype in the system integration laboratory and inform software engineers of the problems. Software engineers connect to the Moxa UC-8100 and check the system over the Ethernet port of the control unit and console outputs (RS-422 and USB consoles) of all units. The log files of all units can be retrieved over the Ethernet connection. If there is a new version of the software, it will be uploaded to the units over this remote connection.

We are going to extend this remote functionality by adding some scripts to the UC-8100 for automatic retrieval and backup of logs and health information of the units during long test periods.

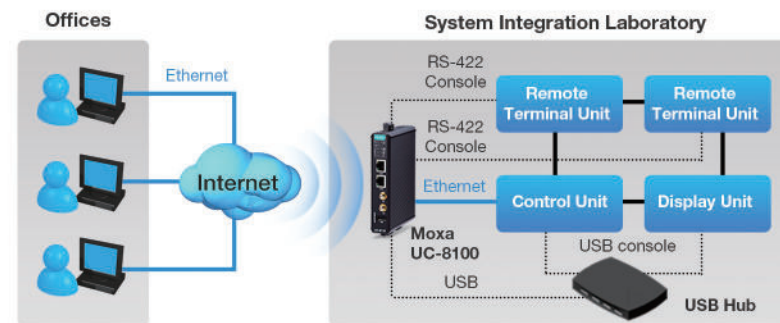

Q: What were the most important features of the UC-8100 for this application?

- A:**
- Dual Ethernet for intra and local networks
 - Serial ports for the units with serial consoles
 - USB port for the units with USB-UART consoles

Q: What additional features would you like to see in the UC-8100 series?

A: The UC-8100 series is a good fit for our application. An additional USB port would be nice. This second USB port might have prevented us from using an extra USB hub. A few additional GPIO might be helpful for some other applications.

Q: What improvements would you suggest for the UC-8100 series RISC computer? Why?

A: Terminal software (minicom, cutecom, etc.) can be installed by default. The toolchain is missing on Moxa's support site. Serial ports can be isolated. We also use isolated USB-UART modules from Moxa. Some other non-isolated ones did not last long.

Quick Facts

Expert Reviewer: Warrell Harries

Application: Railway Wayside Monitoring

Location: United Kingdom

Product Review Q&A

Q: Why did you choose a UC-8100 RISC computer?

- A:**
- We required an OTC robust, small footprint, industrial standard embedded Linux device to process data from multiple RS-485 field units
 - To investigate how much of our software stack can be deployed and configured onto the device without changes to our provisioning system
 - To generate comparative metrics with respect to our internally developed product

Q: For what application did you use the UC-8100 series RISC computer?

A: A Linux Apache MySQL Python application that manages remote railway condition monitoring devices communicating over RS-485. The application generates web-based visualizations of the long term trend data.

Q: What were the most important features of the UC-8100 for this application?

- A:**
- Industrial strength reliability
 - Compliant implementation of Debian Linux distribution
 - Ability to revert to factory default configuration



Q: What additional features would you like to see in the UC-8100 series?

A: The UC-8100 meets our requirements for RS-485/232 but we could use some on-board Digital and Analog I/O capability beyond GPIO

Q: Does the performance of the UC-8100 series RISC computer meet the needs of your application?

A: Yes

Q: What improvements would you suggest for the UC-8100 series RISC computer? Why?

A: More sample applications especially with respect to interface to monitoring equipment



UC-8100 Wireless Computer



Small and Scalable

- Compact, space saving form with a DIN rail mount for easy installation
- Lots of room for memory expansion using either SD or mini SD cards
- Mini PCIe socket makes cellular and modular upgrades a simple task
- Adjust platform capabilities and save on development costs by a range of pin-to-pin-compatible RISC CPUs



Easier Management

- Rich variety and depth of community-developed applications of the Debian ARMv7 system
- Programmable LEDs make debugging and troubleshooting much easier work
- Native support for Modbus, for convenient sensor installation



Stronger Security

- Built-in TPM with the strongest commercial firewall protection: EAL4+ compliant security
- Patented secure boot technology uses a dynamic encryptor to safeguard your Linux kernel
- SD write protection guarantees OS integrity



Wide-Temp Tolerance

- -40 to 75°C operating temperature models available for harsh environments
- Industry leading fanless design base on extraordinary thermal solution