

# Keep Your Connectivity on the Right Track



## 1 OCC & ICS Comm.

## 2 Network Backbone

## 3 Interlocking System

## 4 T2G Comm.

## 5 Traction Substation

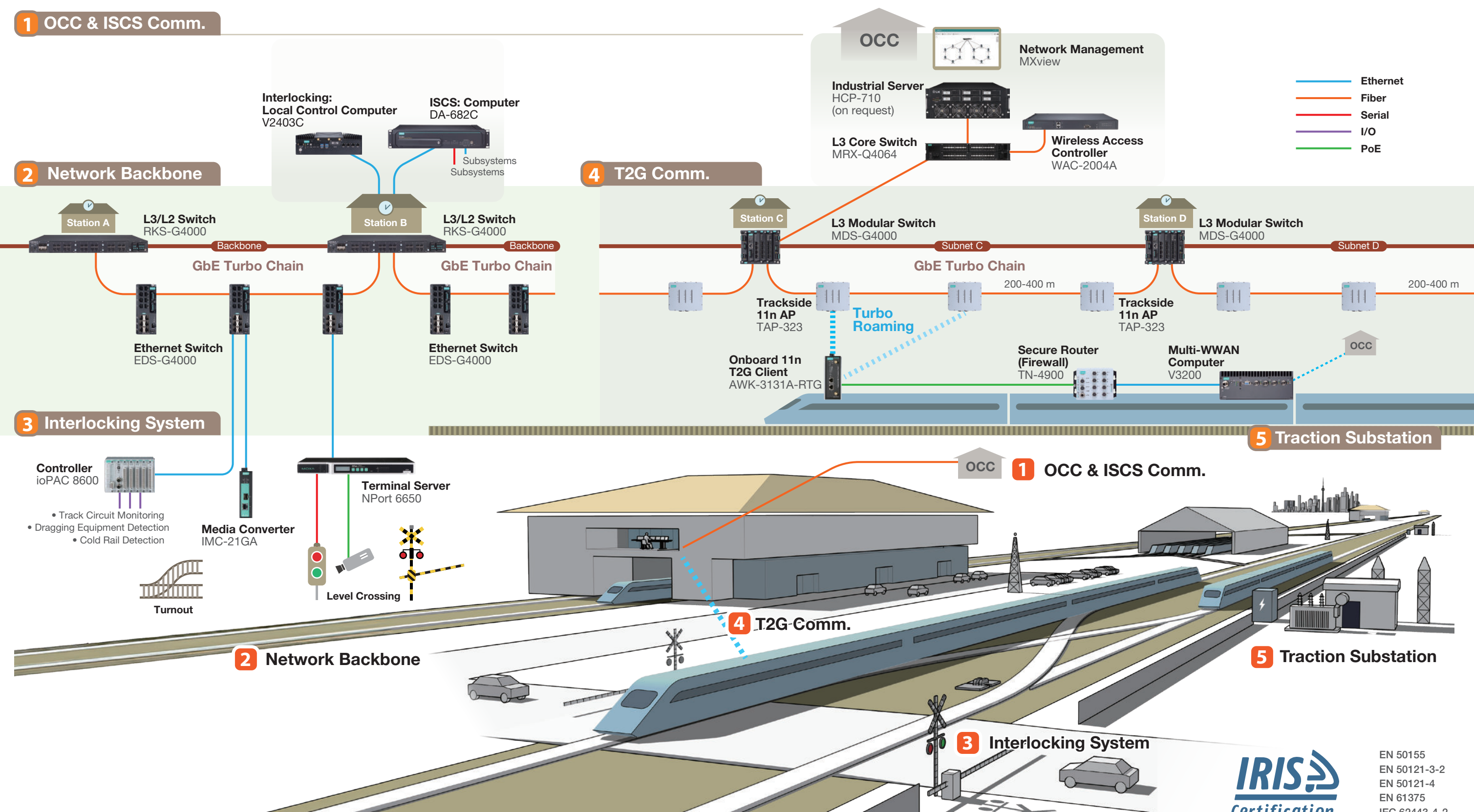

## Moxa Rail Global Credentials

### Extensive Experience

15+ years of rail experience with dedicated RD and business teams

### Industry Collaboration

Co-developing rail industry standards

### Worldwide Successes

1,000+ successful deployments in a variety of rail systems

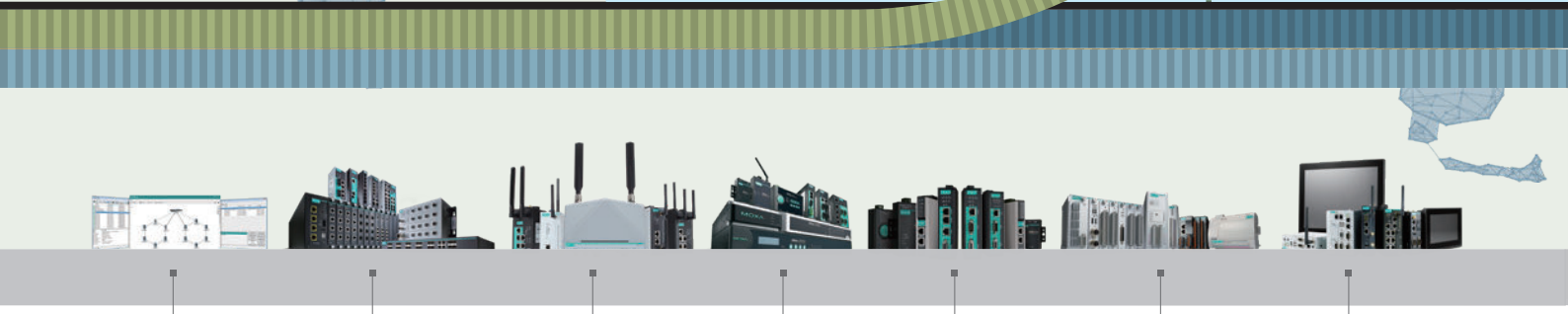

- Industrial NMS
- Industrial Ethernet Switches
- Secure Routers
- Industrial Wireless
- Serial Device Servers
- Protocol Gateways
- I/O
- Industrial Computers

# Keep Your Connectivity on the Right Track

**FORGING MOBILITY AHEAD**  
En route to smarter, safer transportation



EN 50155  
EN 50121-3-2  
EN 50121-4  
EN 61375  
IEC 62443-4-2

© 2024 Moxa Inc. All rights reserved. The MOXA logo is a registered trademark of Moxa Inc. All other logos appearing in this document are the intellectual property of the respective company, product, or organization associated with the logo.



# Seamless Train-to-ground Network Coverage

Train-to-ground (T2G) communication is an important part of onboard CCTV and PIS applications. Operators leverage the CCTV systems to check video footage when the train is on the move or at the station. When the train is docked at a depot, large amounts of video data is uploaded to the control center. For PIS systems, train-to-ground communication is crucial to keep information on the train up to date.

LTE and Wi-Fi are two leading technologies when designing T2G communication infrastructure. In some cases, customers may consider adopting LTE and Wi-Fi hybrid solutions for handling T2G communication in different situations such as when streaming to the OCC or when stationed at a depot.

Moxa provides options to cover both Wi-Fi and LTE needs.

## Enable Live CCTV Streams to the OCC Via Wi-Fi While on the Move

To enable seamless roaming over an average distance of 200 meters, trackside wireless APs are essential. The trackside radios, key components in this architecture, connect to ruggedized trackside backbone switches via fiber-optic connections for reliable and efficient communication.

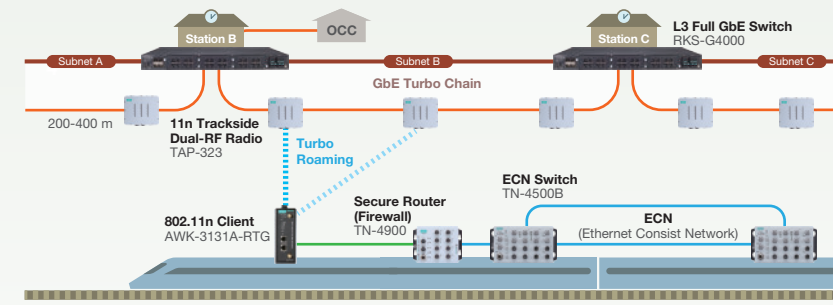

## Achieve Real-time Cellular Cross-regional Connectivity

Trains crossing different geographical regions will need to transition seamlessly between multiple regional network carriers.

Moxa's T2G computing platform meets the demand for resilient connectivity through support for up to three cellular modules and one Wi-Fi module. Designed for multi-network and transnational services, it enables seamless switching between carrier networks, ensuring uninterrupted data streaming and reliable connectivity for the train's operational and communication needs.

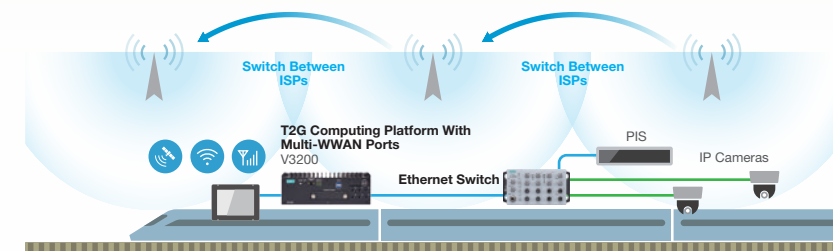

## Offload CCTV Data to Stations/Depots via Wi-Fi

When entering a station or returning to the depot, the train offloads all onboard data via Wi-Fi. The 802.11n clients on the train connect to strategically placed APs at the station or depot to quickly offload all data to the local control center. Wi-Fi streamlines data transfers and reduces carrier service charges by minimizing cellular data usage during the offloading process.

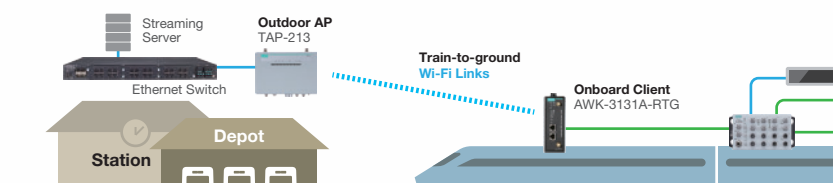

# Resilient Redundancy Backbone



## Broad Choice of Interfaces

- L3/L2 Ethernet switches with high-density 10GbE/GbE/Fast Ethernet/PoE+/fiber-optic connectivity



## Solid Redundancy

- Gigabit Ethernet recovery times under 50 ms with Turbo Ring
- Unrestricted, flexible topology expansion with Turbo Chain



## Robust Cybersecurity

- IEC 62443 security devices
- Vulnerability management

## Build Resilient and Reliable Networks

To monitor the traffic and environmental conditions in real time, it's necessary to build resilient Ethernet networks with reliable backbone switches and data communication equipment to connect the various train subsystems such as station CCTV and AFC systems.

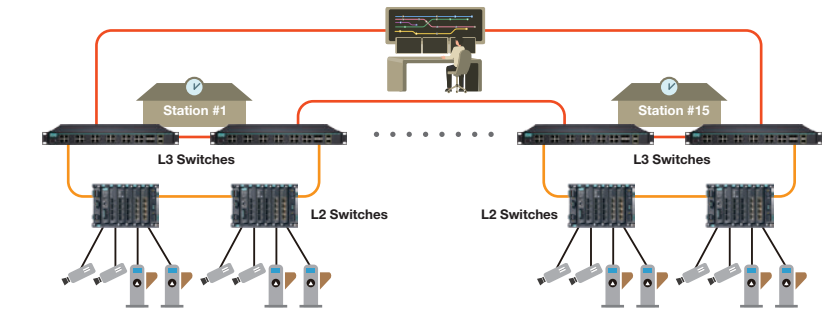

# Simplified OCC & ISCS Communication Management



## Wide Variety of Communications

- Wide media and protocol support
- Serial-to-Ethernet conversion
- L2 and L3 Ethernet switch options



## Simplified Network Management

- MXstudio presents all network settings, conditions, and traceable records through a visual, engineer-friendly interface

## OCC & ISCS Communication Management

The operations control center (OCC) is the brain that manages the day-to-day activities of transportation operators. Communication management is mission-critical for the OCC to ensure smooth operations, correct user access, and efficient management of local stations.

The integrated supervisory control systems (ISCS) enable centralized, local control as well as remote supervision of electrical and mechanical subsystems at stations.

These subsystems include tunnel ventilation, escalators, air conditioning, power supplies, lifts, fire alarms, lighting controls, and access management.

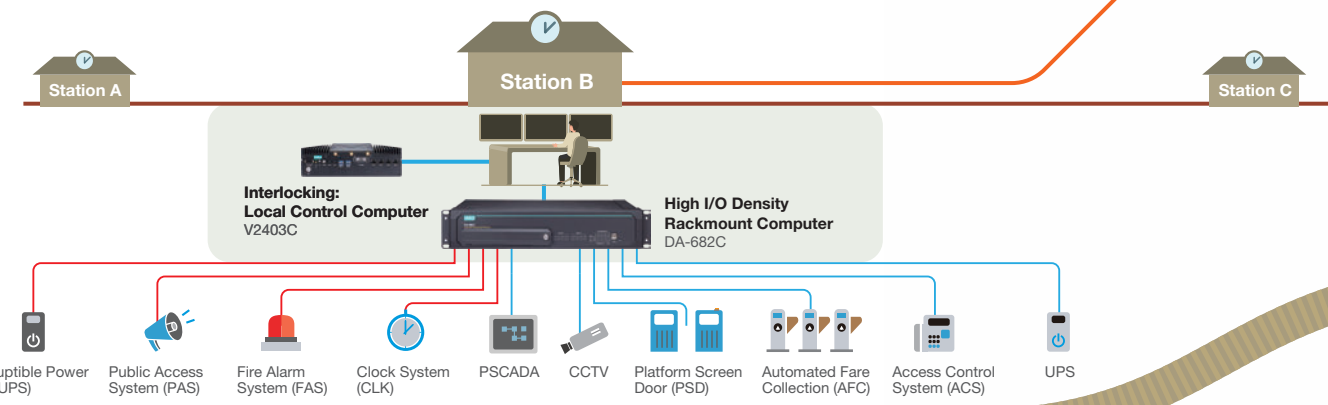

# Safe Interlocking Control



## High-bandwidth Wired Network

- High-performance 10GbE/GbE wired speeds



## Exceed IEEE 1613 Class 2 Requirements

- NoiseGuard™: Wire-speed zero packet loss technology
- Layer 3 to protect against broadcast storms across stations

## Mainline Interlocking Network Communications

Interlocking systems are the core of route control for mainline and urban rail. They provide safe routes (pathways) by managing the condition of signals, points machines, level crossings, and all other field components.

A reliable communication network is necessary to transmit this condition data to the control center, allowing operators to manage these systems efficiently.

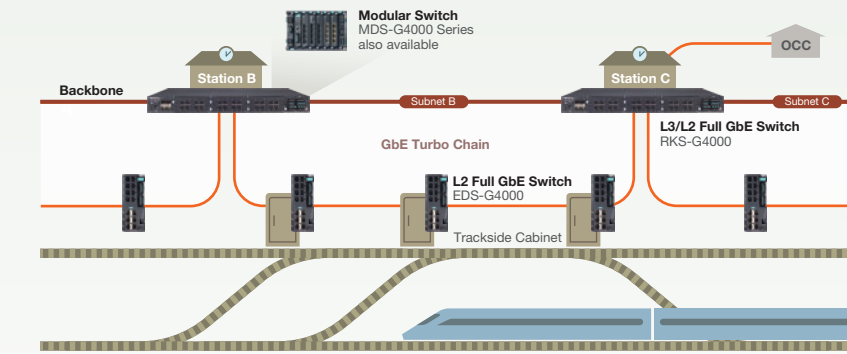

## Interlocking Control System

The signal apparatus arrangement prevents conflicting movements in track configurations. Trackside equipment, including turnout control and ATP, connects to a Layer 3 Ethernet switch. The interlocking system, at the core of signaling, gathers and processes data from trackside equipment via the Ethernet switch. It converts this information and transfers relevant data to CTC through networking. The Layer 3 Ethernet switch manages both intra-station and inter-station networking, utilizing routing protocols and VLAN segregation for efficient information flow.

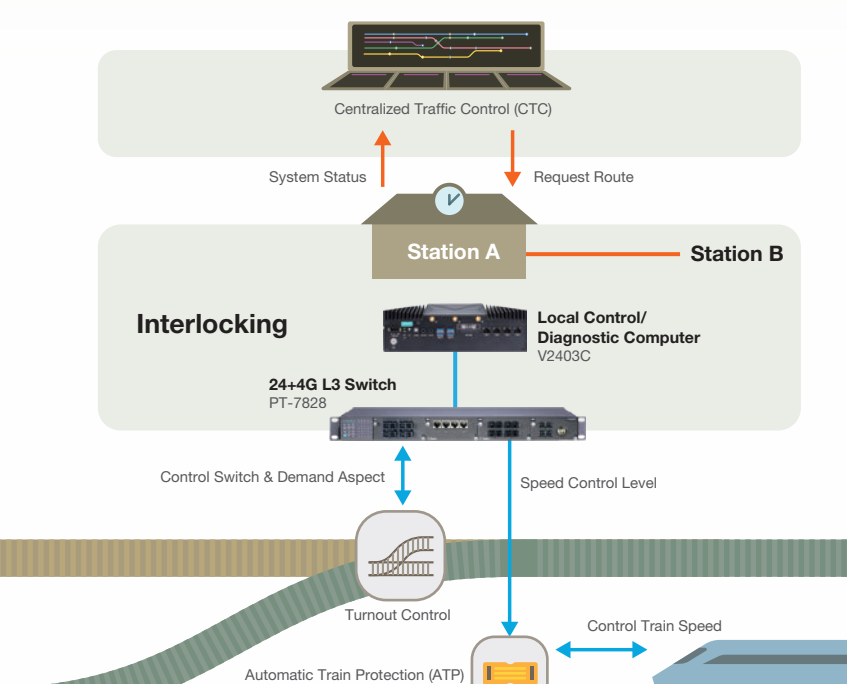

# Superior IEC 61850 Substation Deployment Experience

## Solutions for IEC 61850 Traction Substations

Primary and secondary traction substation equipment, interface standards, and technical equipment levels vary between different regions. To address this issue, IEC 61850 provides a common standard for substation communication systems. This aims to streamline communication between widely accepted existing standards, achieve interoperability between intelligent electronic devices (IEDs) from different manufacturers, and adapt to rapid developments in communication and application technology.

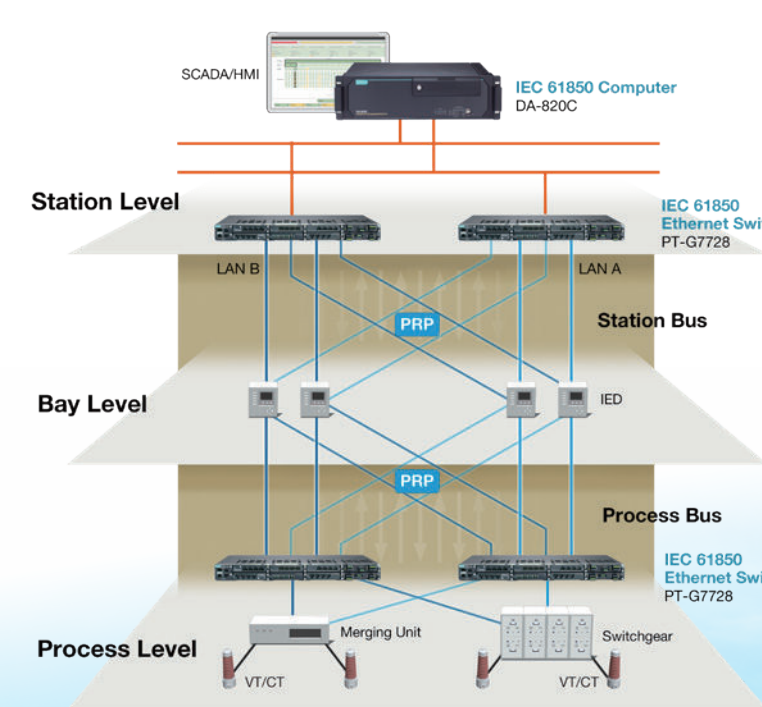

### About Moxa Energy

- 15+ years of experience in the energy industry
- 9000+ SAS deployments worldwide
- Dedicated Energy business team
- Participation in international associations and organizations (IEC, WG, CIGRE WG, UCAIug)
- Leader in IEC 61850 and PRP/HSR communication and computing technologies

