

## High I/O Density for Efficient Data Processing

x86 platform with expandable GbE  
and serial interfaces



### Rackmount Data-Acquisition Computing Solution

High-performance industrial-grade computing platforms built for the heavy data processing needs of power, rail, factory, and building automation applications



High Flexibility



Proven Reliability



Easy Maintainability

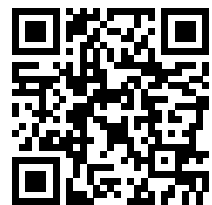

Scan this QR code  
to learn more or visit  
[http://www.moxa.com/  
product/DA-720-DPP.htm](http://www.moxa.com/product/DA-720-DPP.htm)



# One Computer to Connect All Your Devices

With more and more companies implementing IIoT applications, the demand to connect hundreds or thousands of devices to industrial automation systems has increased dramatically. The DA-720, a high-performance industrial-grade x86 platform, is ideal for such applications. It is based on the Intel® 6th Gen Skylake processor and provides a high density of gigabit Ethernet and serial ports in a 19-inch 2U rack-mountable case, making it an ideal choice for IIoT applications in power substations, railway, factory, and building automation systems.



## High Flexibility for Versatile Applications

The DA-720 comes with high-performance Intel® Core™ i5 or i7 CPU options that allow system designers to install the mSATA, RAM, and operating system according to their application requirements. The computer is also provided with expandable serial and Ethernet interfaces to enable easy connectivity with a large number of field devices that have various data processing needs.

- Intel® Core™ i7, 2.6 GHz, dual-core CPU or i5, 2.4 GHz, dual-core CPU (Skylake)
- High I/O density with up to 22 gigabit LAN ports plus 10 serial ports, or 14 gigabit LAN ports plus 18 serial ports
- 2 built-in DDR4 memory sockets with up to 32 GB capacity
- 110 to 240 VDC and 100 to 240 VAC power inputs



## High Reliability to Ensure 24/7 Operation

Moxa's DA-720 series rugged computers are designed to operate reliably in harsh industrial environments. They have passed rigorous tests for adherence to safety standards, including continuous exposure to high voltage, power surges, and shock. The DA-720 is a perfect choice for your power, rail, factory, and building automation applications.

- Compliance with IEC 61850-3, IEC 60255, and IEEE 1613 for power automation
- Compliance with EN 50121-4 for rail automation
- Moxa's patented fanless heat dissipation technology
- PRP/HSR support to establish network redundancy for high network availability



## Easy Maintainability to Reduce System Downtime

Automation computers are often located at unmanned or remote sites. To ensure maximum uptime, the DA-720 supports Moxa's Proactive Monitoring utility, which provides real-time information about the status of the computer hardware and triggers alerts based on user-defined criteria for predictive maintenance. The Smart Recovery utility allows engineers to automatically trigger OS recovery at remote locations to minimize system downtime.

### Proactive Monitoring

- Remote key-part monitoring
- Ready-to-use Ethernet-based remote alarm solution
- APIs for easy integration with external applications, including dashboards

### Smart Recovery

- Fully automated OS recovery
- Easy-to-use two-step manual recovery process



## IEC 61850 Smart Substation

The role of computers in a smart substation has expanded from merely providing computing power to more critical roles such as analyzing, monitoring, and controlling substation processes. A comprehensive control and monitoring system in an IEC 61850 smart substation needs reliable, high-performance computers.

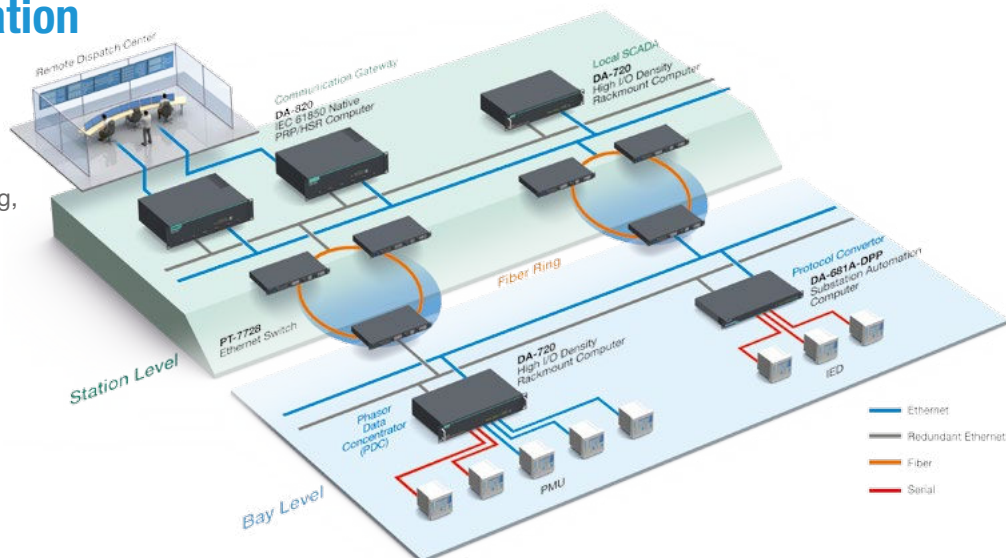

### ► System Requirements

- A high performance solution that can enhance remote asset management and monitoring, as well as transmit various HV data workflows from the MBI and PSE platforms to a centralized SCADA system.
- Multiple gigabit Ethernet ports with flexible port configuration support to enable control and monitoring of IEDs.

### ► Why Moxa?

- High performance computer with 6th Gen Intel® Core™ i7 or i5 CPU and up to 32 GB DDR4 memory capacity
- Compliance with IEC 61850-3, IEEE 1613, and IEC 60255 standards
- Modular design with a high density of communication ports to collect data from IEDs
- Value-added ready-to-use computer with self-maintenance function

## Substation Retrofitting

The focus of a substation retrofit project is deploying IEDs to make the primary equipment more intelligent and converting analog data into digital data and protocols to serve the secondary equipment in the substation bus networks. Therefore, a key success factor in substation automation is the ability to connect to all types of devices, collect data from the devices, and integrate the data into a powerful and reliable control system.

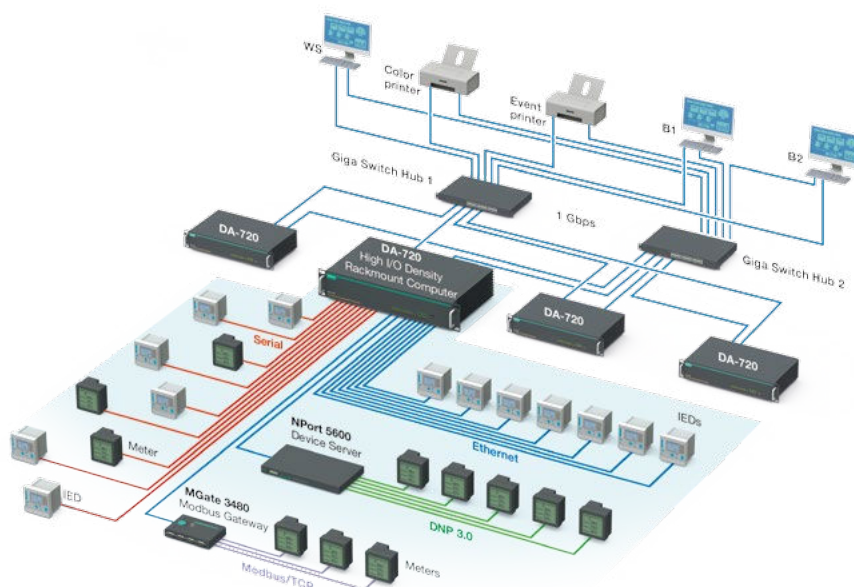

### ► System Requirements

- A solution that provides the ability to connect to a large number of serial and Ethernet based IEDs for substation retrofits
- A substation-grade, reliable, and easy-to-use management platform to maximize system uptime

### ► Why Moxa?

- Industrial-grade, fanless, and cableless design guarantees system longevity
- Compliance with IEC 61850-3, IEEE 1613, and IEC 60255 standards for substation automation
- High density of ports and connection interfaces: 14 Gigabit LAN and 18 serial ports
- Value-added ready-to-use computer with self-maintenance function

## Rail Integrated Supervisory Control System

Multiple railway automation subsystems, such as PIS, PA, CCTV, PSD, Power SCADA, and ACS, have evolved to provide a safe and fast travel experience to passengers. An Integrated Supervisory Control System (ISCS) is used to manage all these subsystems. Operators at the train station use data from the ISCS to monitor and control rail operations. As more and more subsystems are integrated into the core rail system, increasing the complexity of the networks and communication interfaces, the use of ISCSs with front-end processors in rail automation systems is increasing.

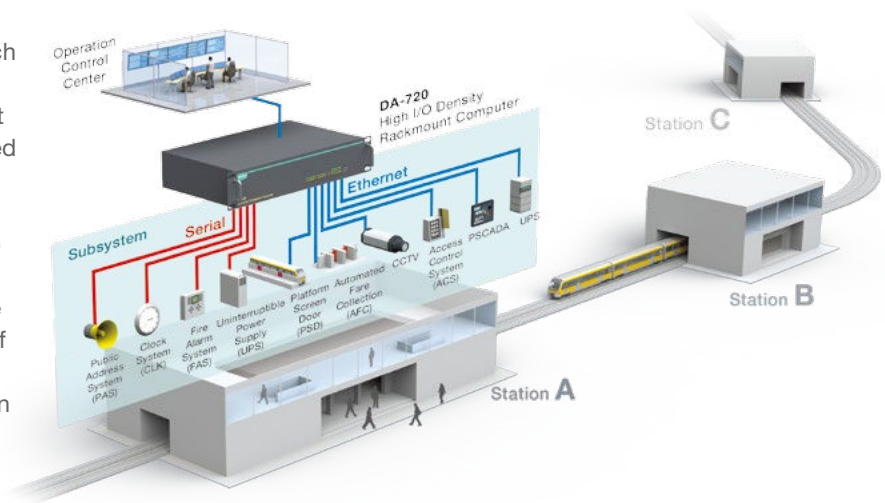

### ► System Requirements

- A reliable and easy-to-use platform that maximizes system uptime
- A solution that provides isolated LAN ports to connect to more than 10 independent subsystems for effortless system expansions

### ► Why Moxa?

- Industrial-grade, fanless, and cableless design guarantees system longevity
- Compliance with EN 50121-4 standards for rail automation
- High density of ports and connection interfaces: Up to 22 Gigabit LAN and 10 serial ports
- Proactive Monitoring function in computers for effective management and maintenance

## Wayside Traction Power System Management

A traction power substation converts the electrical power supplied by a power utility company before it is transmitted to a rail system, either through third rail systems or overhead lines. Depending on the type of the rail system, power is supplied either as direct current (DC) or alternating current (AC). Traction substations often have to meet harsher operational and stability standards as compared to power distribution substations on account of their exposure to frequent short circuits, transient spikes, and voltage fluctuations.

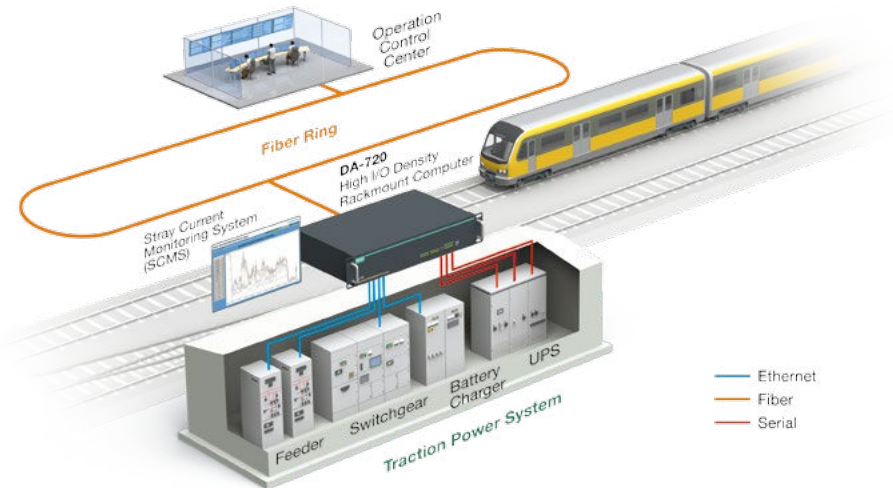

### ► System Requirements

- An industrial-grade computer that is designed to operate in harsh environments
- A solution that provides the ability to connect to a large number of serial sensors and Ethernet devices to simplify network connectivity

### ► Why Moxa?

- Industrial-grade, fanless, and cableless design guarantees system longevity
- Compliance with EN 50121-4, IEC 61850-3, IEEE 1613, and IEC 60255 standards
- Proactive Monitoring function in computers for effective management and maintenance

## Device Control—Dry Pump Monitoring System

Device control systems, such as GIS, dry pump, and local scrubber systems, are critical elements of a facility management and control system (FMCS). Typically, there are hundreds of devices in an FMCS that need to be managed, with most of them located in remote areas. The management platform must have the ability to connect to all of these devices and should help optimize and maximize the overall equipment effectiveness (OEE).

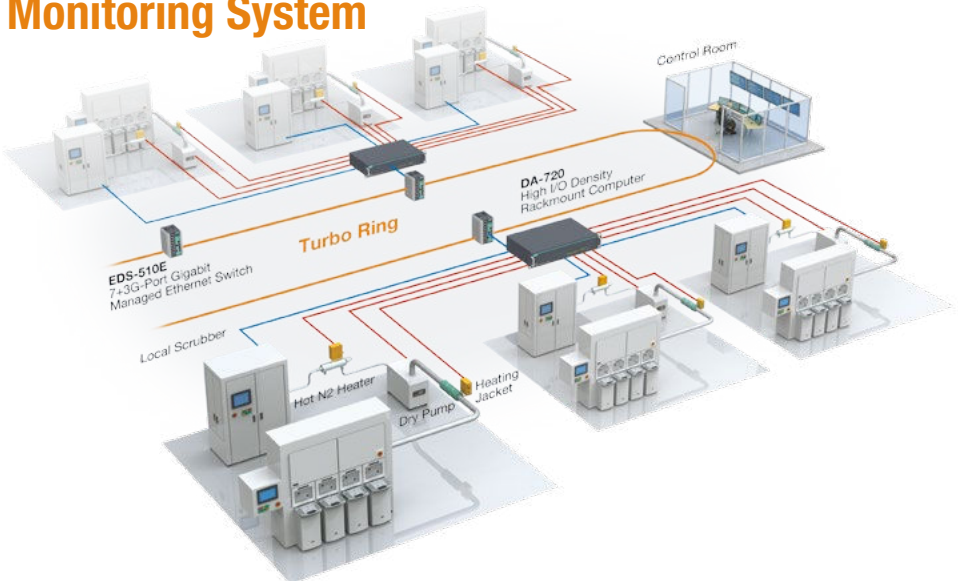

### ► System Requirements

- Protocol conversion among different dry pump devices
- Reliable network performance in harsh environments subject to electrical interference
- Real-time dry pump data acquisition, storage, and management for predictive system maintenance and minimized system downtime

### ► Why Moxa?

- Industrial-grade ruggedness, including fanless, cableless, and EMC Level 4 design
- High I/O density embedded computer that supports up to 14 Gigabit LAN and 18 serial ports for maximum device connectivity

## Power and Environmental Monitoring System

Environmental control and monitoring systems, such as UPS, HVAC, access control, lighting control, and fire alarm systems, are critical elements of a facility management and control system (FMCS). When monitoring and analyzing the large amount of diverse data from these systems, it is essential to select a reliable, high-performance computing platform that is optimized for data-acquisition and protocol-conversions.

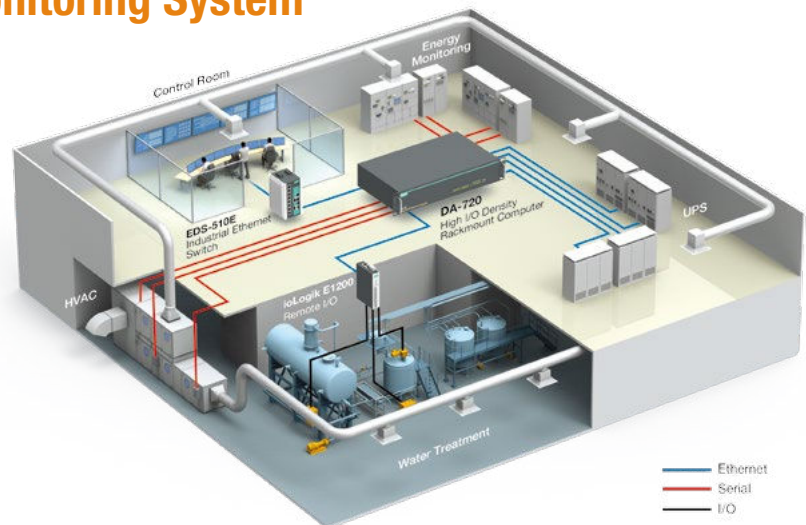

### ► System Requirements

- A critical application that requires high system stability and longevity
- Remote monitoring capability to monitor unmanned sites
- Ability to operate in high-noise environments

### ► Why Moxa?

- Fanless design for longevity
- Industrial-grade network solution with level 4 EMC protection
- Proactive Monitoring and Smart Recovery to minimize downtime

3U



2U



2U



1U



1U



Model Name	DA-820	DA-720-DPP	DA-682A-DPP	DA-681A-DPP	DA-662A
CPU Speed	2.1 GHz / 2.5 GHz	2.4 GHz / 2.6 GHz	1.4 GHz / 1.6 GHz / 1.7 GHz	1.4 GHz	500 MHz
OS (Preinstalled)	–	Linux Debian 8	Linux Debian 8	Linux Debian 8	Embedded Linux
OS (Optional)	Linux Debian 7 / Windows 7E	Windows 10	Windows 7E	Windows 7E	–
Built-In Storage	–	8GB mSATA for Linux	2GB DOM for Linux	8GB mSATA for Linux	–
Storage Expansion	4 x SATA 2.0 RAID 0 / 1 / 5 / 10	1 x SATA 3.0	2 x SATA 2.0	1 x SATA 3.0	–
LAN Ports	4 x 10 / 100 / 1000 Mbps	14 x 10 / 100 / 1000 Mbps	6 x 10 / 100 / 1000 Mbps	6 x 10 / 100 / 1000 Mbps	4 x 10 / 100 / 1000 Mbps
Serial Ports	2 x RS-232 / 422 / 485 (DB9 male)	2 x RS-232 / 422 / 485 (terminal block)	–	• 2 x RS-232 / 422 / 485 (DB9 male) • 10 x RS-485 (terminal block)	8 to 16 RS-232 / 422 / 485 (8-pin RJ45)
Interface Expansion	5 slots (standard PCIe and PCI)	3 slots (8-port serial and 4 or 8-port GbE)	2 slots (8-port serial and 8-port switch interface card)	–	–
Dimensions	361 x 440 x 133 mm	440 x 301 x 90 mm	440 x 315 x 90 mm	440 x 315 x 45 mm	480 x 45 x 237 mm
Operating Temperature	• DA-820-C8: -40 to 60°C • DA-820-C7: -40 to 75 °C	-25 to 55°C	-25 to 60°C	• DPP: -25 to 55°C • DPP-T: -40 to 70°C	-10 to 60°C
Power Input	HV : 100 to 240 VAC / VDC LV : 24 to 110 VDC	100 to 240 VAC / 110 to 240 VDC	100 to 240 VAC / VDC	100 to 240 VAC / VDC	100 to 240 VAC
Certifications	IEC 61850-3, IEEE 1613, IEC 60255	IEC 61850-3, IEEE 1613, IEC 60255, EN 50121-4	IEC 61850-3, IEEE 1613, IEC 60255, EN 50121-4	IEC 61850-3, IEEE 1613, IEC 60255	LVD, UL, cUL
Warranty Period	3 years	3 years	3 years	3 years	5 years

## Your Trusted Partner in Automation

Moxa is a leading provider of edge connectivity, industrial computing, and network infrastructure solutions for enabling connectivity for the Industrial Internet of Things. With over 30 years of industry experience, Moxa has connected more than 50 million devices worldwide and has a distribution and service network that reaches customers in more than 70 countries. Moxa delivers lasting business value by empowering industry with reliable networks and sincere service for industrial communications infrastructures.

### Moxa Sales and Marketing Headquarters

Moxa Corporate Plaza  
601 Valencia Ave., Suite 200  
Brea, CA 92823, U.S.A.  
Toll Free: 1-888-669-2872  
Tel: +1-714-528-6777  
Fax: +1-714-528-6778  
usa@moxa.com

### Moxa Design and Engineering Headquarters

Fl. 4, No. 135, Lane 235, Baoqiao Rd.  
Xindian Dist., New Taipei City,  
Taiwan, R.O.C.  
Tel: +886-2-8919-1230  
Fax: +886-2-8919-1231

### The Americas

#### Moxa Americas

Toll Free: 1-888-MOXA-USA  
Tel: +1-714-528-6777  
Fax: +1-714-528-6778  
usa@moxa.com

#### Moxa Brazil

Tel: +55-11-2495-3555  
Fax: +55-11-2495-6555  
brazil@moxa.com

### Europe

#### Moxa Germany

Tel: +49-89-37003-99-0  
Fax: +49-89-37003-99-99  
europe@moxa.com

#### Moxa France

Tel: +33-1-30-85-41-80  
Fax: +33-1-30-47-35-91  
france@moxa.com

#### Moxa UK

Tel: +44-1844-355-601  
Fax: +44-1844-353-553  
uk@moxa.com

### Asia-Pacific

#### Moxa Asia-Pacific and Taiwan

Tel: +886-2-8919-1230  
Fax: +886-2-8919-1231  
asia@moxa.com  
japan@moxa.com  
taiwan@moxa.com

#### Moxa India

Tel: +91-80-4172-9088  
Fax: +91-80-4132-1045  
india@moxa.com

#### Moxa Russia

Tel: +7-495-287-0929  
Fax: +7-495-269-0929  
russia@moxa.com

#### Moxa Korea

Tel: +82-2-6268-4048  
Fax: +82-2-2125-5050  
korea@moxa.com

### China

#### Moxa Shanghai

Tel: +86-21-5258-9955  
Fax: +86-21-5258-5505  
china@moxa.com

#### Moxa Beijing

Tel: +86-10-5976-6123/24/25/26  
Fax: +86-10-5976-6122  
china@moxa.com

#### Moxa Shenzhen

Tel: +86-755-8368-4084/94  
Fax: +86-755-8368-4148  
china@moxa.com