

Your Trusted Partner in Automation

Moxa is a leading provider of edge connectivity, industrial computing, and network infrastructure solutions for enabling connectivity for the Industrial Internet of Things (IIoT). With over 30 years of industry experience, Moxa has connected more than 57 million devices worldwide and has a distribution and service network that reaches customers in more than 70 countries. Moxa delivers lasting business value by empowering industries with reliable networks and sincere service. Information about Moxa's solutions is available at www.moxa.com.

Moxa Americas USA

Toll Free: 1-888-MOXA-USA
Tel: +1-714-528-6777
Fax: +1-714-528-6778
usa@moxa.com

Brazil

Tel: +55-11-95261-6545
brazil@moxa.com

Moxa Europe Germany

Tel: +49-89-37003-99-0
Fax: +49-89-37003-99-99
europe@moxa.com

France

Tel: +33-1-30-85-41-80
Fax: +33-1-30-47-35-91
france@moxa.com

UK

Tel: +44-1844-355-601
Fax: +44-1844-353-553
uk@moxa.com

Moxa Asia-Pacific and Taiwan Asia/Japan/Taiwan

Tel: +886-2-8919-1230
Fax: +886-2-8919-1231
asia@moxa.com
japan@moxa.com
taiwan@moxa.com

India

Tel: +91-80-4172-9088
Fax: +91-80-4132-1045
india@moxa.com

Russia

Tel: +7-495-287-0929
Fax: +7-495-269-0929
russia@moxa.com

Korea

Tel: +82-2-6268-4048
Fax: +82-2-6268-4044
korea@moxa.com

Moxa China Shanghai

Tel: +86-21-5258-9955
Fax: +86-21-5258-5505
china@moxa.com

Beijing

Tel: +86-10-5976-6123/24/25/26
Fax: +86-10-5976-6122
china@moxa.com

Shenzhen

Tel: +86-755-8368-4084/94
Fax: +86-755-8368-4148
china@moxa.com

© 2019 Moxa Inc. All rights reserved.

The MOXA logo is a registered trademark of Moxa Inc. All other logos appearing in this document are the intellectual property of the respective company, product, or organization associated with the logo.

P/N: 1900001801700

MOXA®

Cloud-ready IIoT Edge Gateway Application Guidebook

MOXA®



Embrace the IIoT for a Smarter Future

Industries are adopting the IIoT to interconnect production equipment, machines, and applications across OT and IT networks. By leveraging powerful cloud services and edge computing solutions, IIoT applications can transform large volumes of collected data into actionable intelligence that can drive optimization and predictive maintenance in smart industries, smart cities, and smart utilities.

To accelerate your IIoT application development, Moxa provides the ThingsPro® Software, which simplifies your edge-to-cloud data communication. ThingsPro also provides the option to integrate with on-premise SCADA and popular PaaS and SaaS cloud services for flexible development.

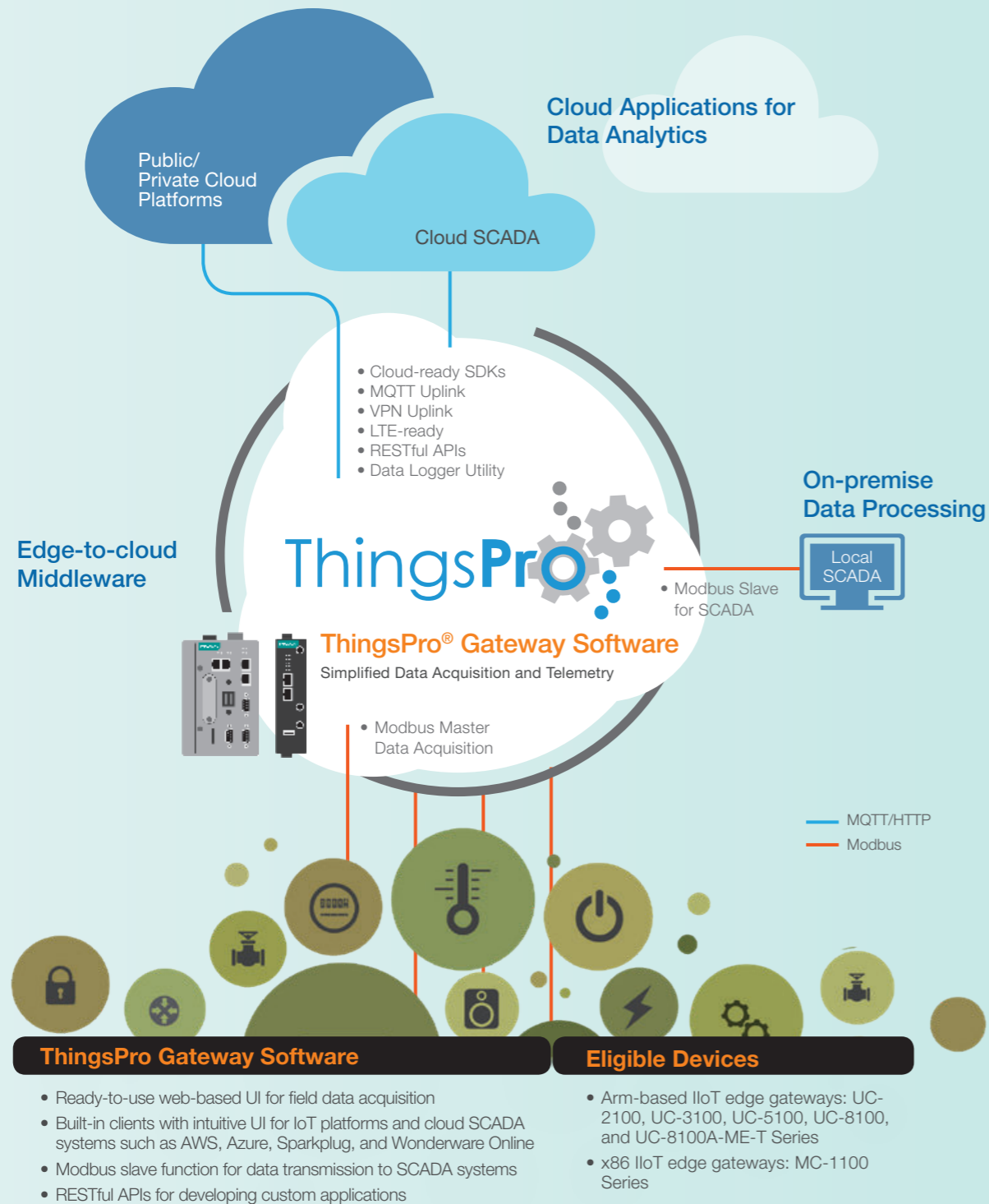

Simplify Your Industrial IoT Deployments

Our ThingsPro Software provides a cloud-ready gateway solution for easy and secure connectivity between edge and cloud, ensuring transparent data exchange between OT and IT systems. In addition, you can leverage modern RESTful APIs to transform data to actionable insights for smart diagnostics and communication between heterogeneous systems.

Edge-to-cloud Data Acquisition

- Intuitive web-UI for tag-centric data acquisition
- Modbus slave for a data uplink to your Local SCADA
- Data converter for Modbus-to-MQTT conversion

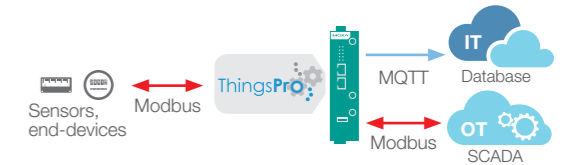

Cloud-ready

- Built-in IIoT clients/SDKs with intuitive UIs to cloud service providers such as AWS and Azure
- Built-in clients/SDKs with intuitive UIs to cloud SCADA services such as Ignition and Wonderware Online

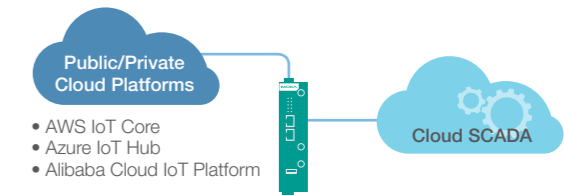

RESTful APIs

- Helps you create custom dashboards for flexible monitoring and easy reporting
- Allows real-time edge data processing thereby reducing network latency and complexity issues



Edge Computing

- Facilitates user programs to collect, process, and tag data, at the edge, and convert the data for usage in cloud applications

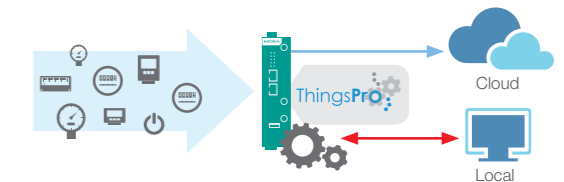

Secure Transmission

- VPN-ready for secure remote access
- TLS 1.2 support for secure data transmission

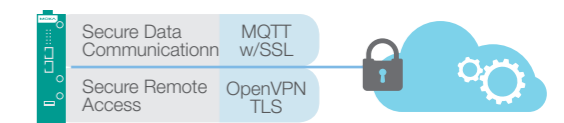

Smart Routing

- Ethernet-to-cellular routing for easy WAN access
- Ethernet/cellular routing for redundant WAN access

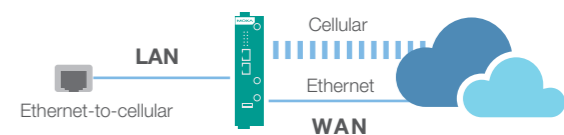

Reliable Connectivity

- Keep-alive check for LTE stability
- Temporary data save and resend function when the network is down

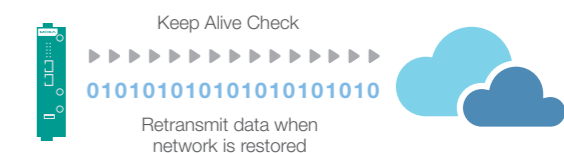



Solar Power Plant Monitoring and Control System

A utility-scale solar power plant can consist of hundreds to thousands of solar collectors. Solar power plant operators need to collect and process data from numerous devices located at remote sites to achieve high energy efficiency.

System Architecture

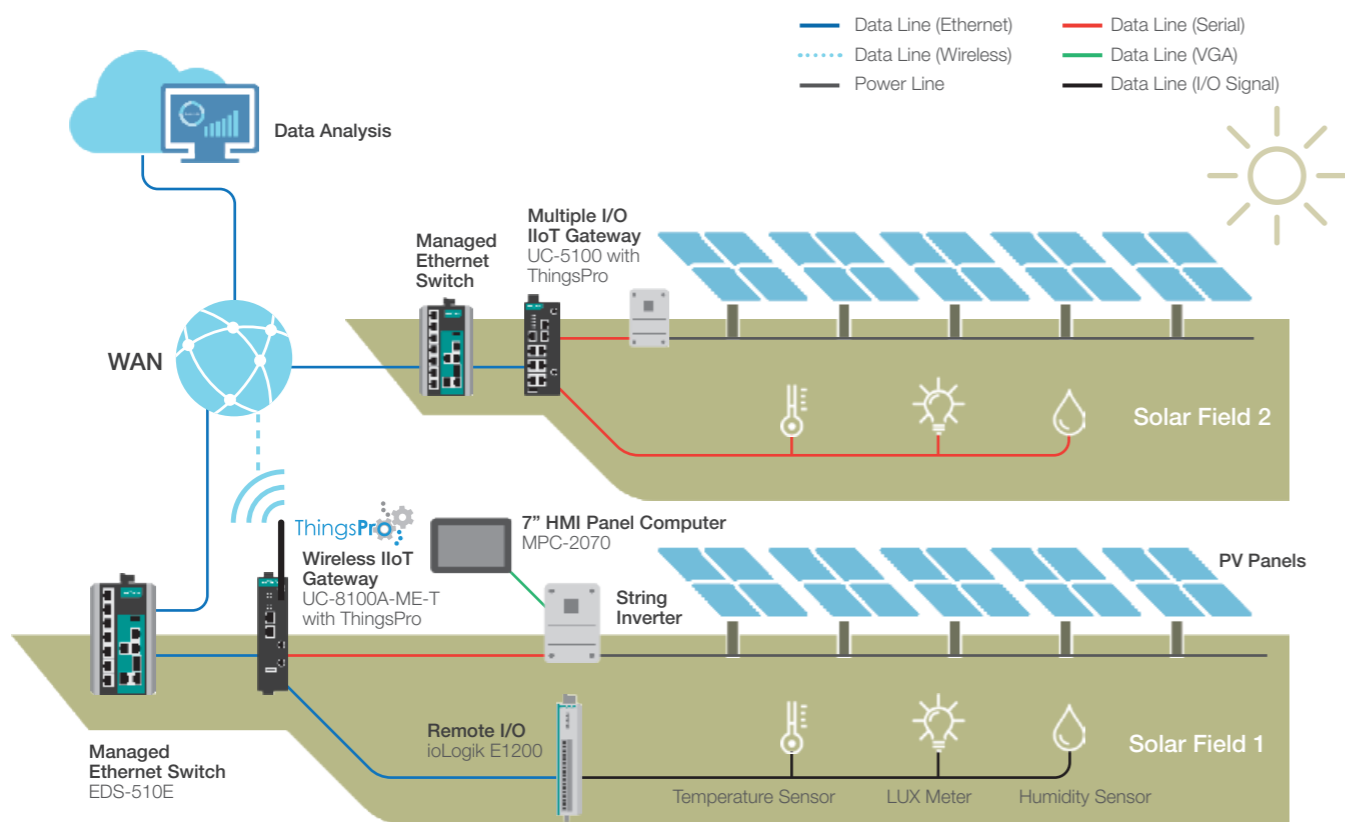

Residential Solar Power Monitoring System

Residential solar systems are seeing a rapid growth thanks to clean energy initiatives, tax incentives, and professional solar service providers. Solar service providers are helping home owners sell the excess energy they produce to utility companies and also provide facility maintenance services. The adoption of IIoT to monitor the operation of distributed solar systems is helping solar service providers achieve just-in-time maintenance.

System Architecture

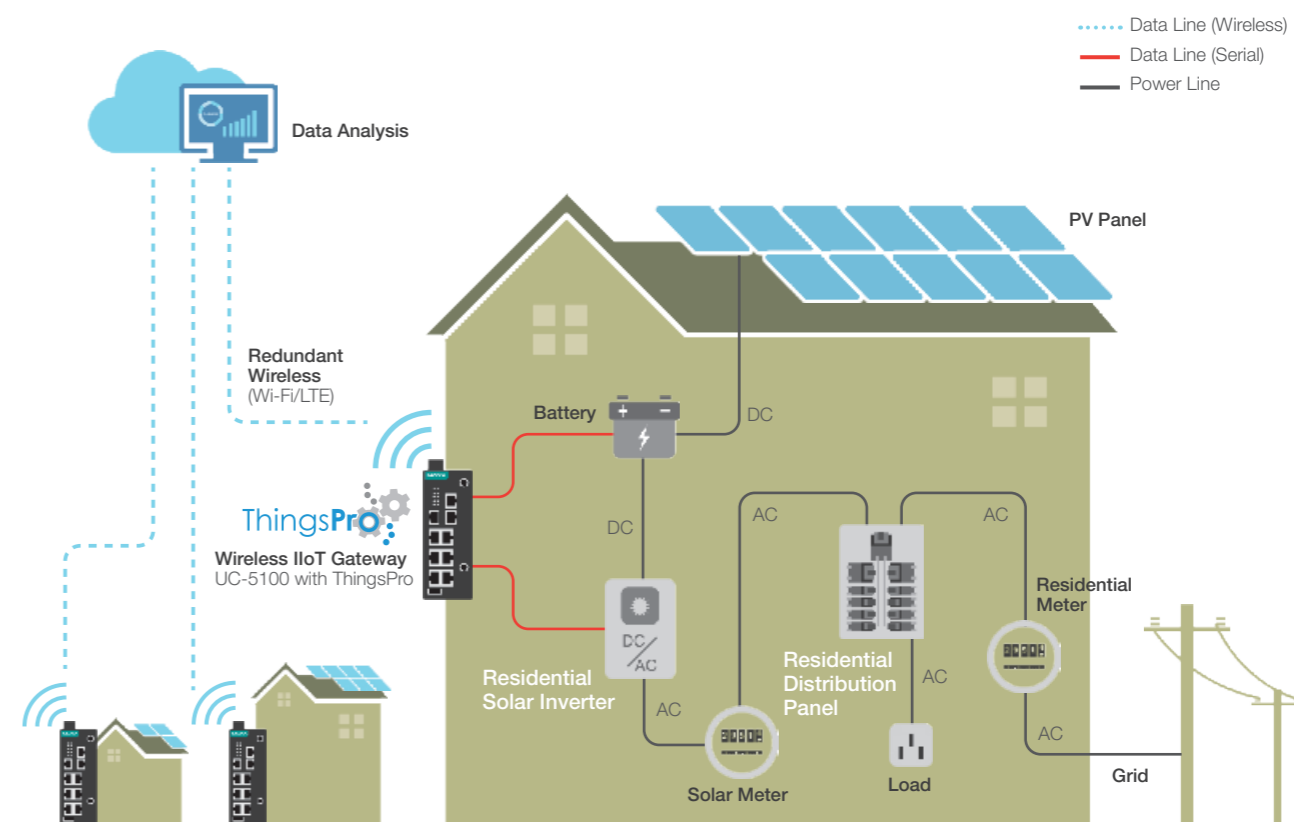

System Requirements

- Data acquisition from thousands of remote locations
- Web-based monitoring of the performance of distributed solar arrays, battery load in the storage systems, and environment sensors
- Sunlight-readable HMI for inverter control
- Operational reliability

Why Moxa

- One-stop-shop solution for industrial I/Os, switches, and computers that can withstand extreme temperature conditions for non-stop operation
- Rich I/O and fieldbus protocol capabilities to collect data from a high volume of sensors and end-devices
- Built-in ThingsPro Gateway software that enables secure data tunnels and Modbus-to-MQTT conversion for data import into cloud systems
- MPC-2070 panel PC with 1000-nit display for sunlight-readable operation

System Requirements

- Easy and reliable wireless connection to ensure integrity of energy usage and billing data
- Open platform for flexible application development

Why Moxa

- Moxa's Arm-based UC-5100 Series computers provide both 4G LTE and Wi-Fi connectivity
- ThingsPro gateway software on the UC-5100 enables data acquisition through a Modbus agent and Modbus-to-MQTT conversion for IT friendly data uploads
- Keep-alive check ensures continuous LTE connections
- Temporary save and resend function retransmits data when the network is restored



Remote Asset Management for Intelligent Transportation Systems (ITS)

Intelligent transportation systems are already an essential part of people's daily lives. Keeping such a complex system operating smoothly is a big challenge for transportation authorities who typically incur high costs by sending personnel to sites where equipment has malfunctioned. The key challenge is to quickly identify the devices that have failed in the field.

System Architecture

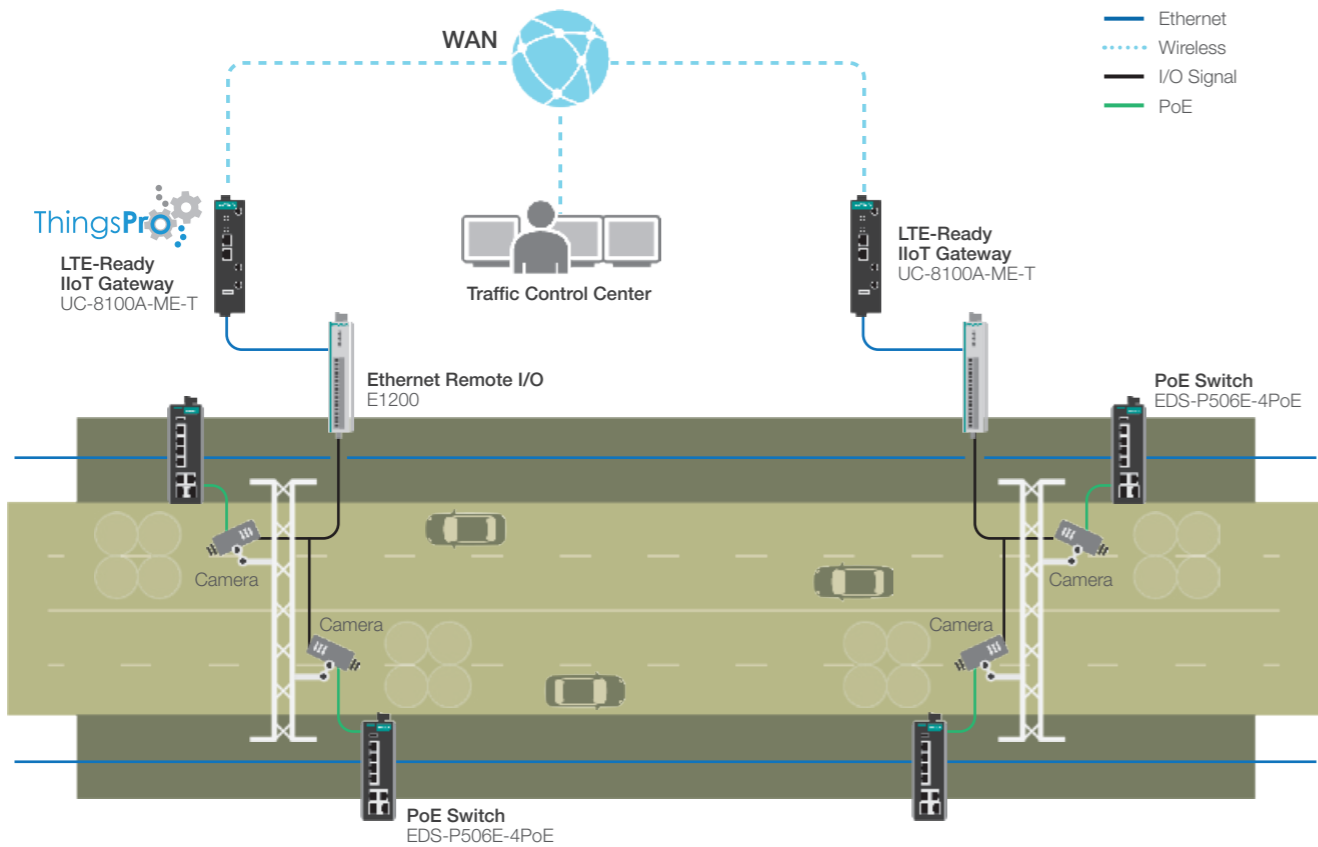

System Requirements

- Perform remote monitoring reliably in outdoor environments
- Track the health of PTZ cameras to implement preventative maintenance thereby reducing downtime
- Redundant monitoring for PTZ cameras

Why Moxa

- UC-8100A computer with LTE connectivity to report the status of PTZ cameras connected to I/Os
- Both the UC-8100A computers and EDS-P506E-4PoE switches can operate in the -40 to 70°C temperature range
- SDKs for AWS and Azure cloud platforms for easy access to cloud APIs
- The EDS-P506E-4PoE PoE switches transmit data and provide DC power up to 60 W for each PTZ camera
- The PoE switches also perform failure-checks of IP cameras and reboot them after timeout expired



Geographic Information Systems for Natural Disaster Warning

Disaster prevention is crucial to reducing the vulnerability of people and property to Natural disasters and calamities. Disaster prevention research centers are using Geographic Information Systems (GISs) to monitor and analyze various types of environmental measurements and use it to look for early warning signs or to forecast potential hazards.

System Architecture

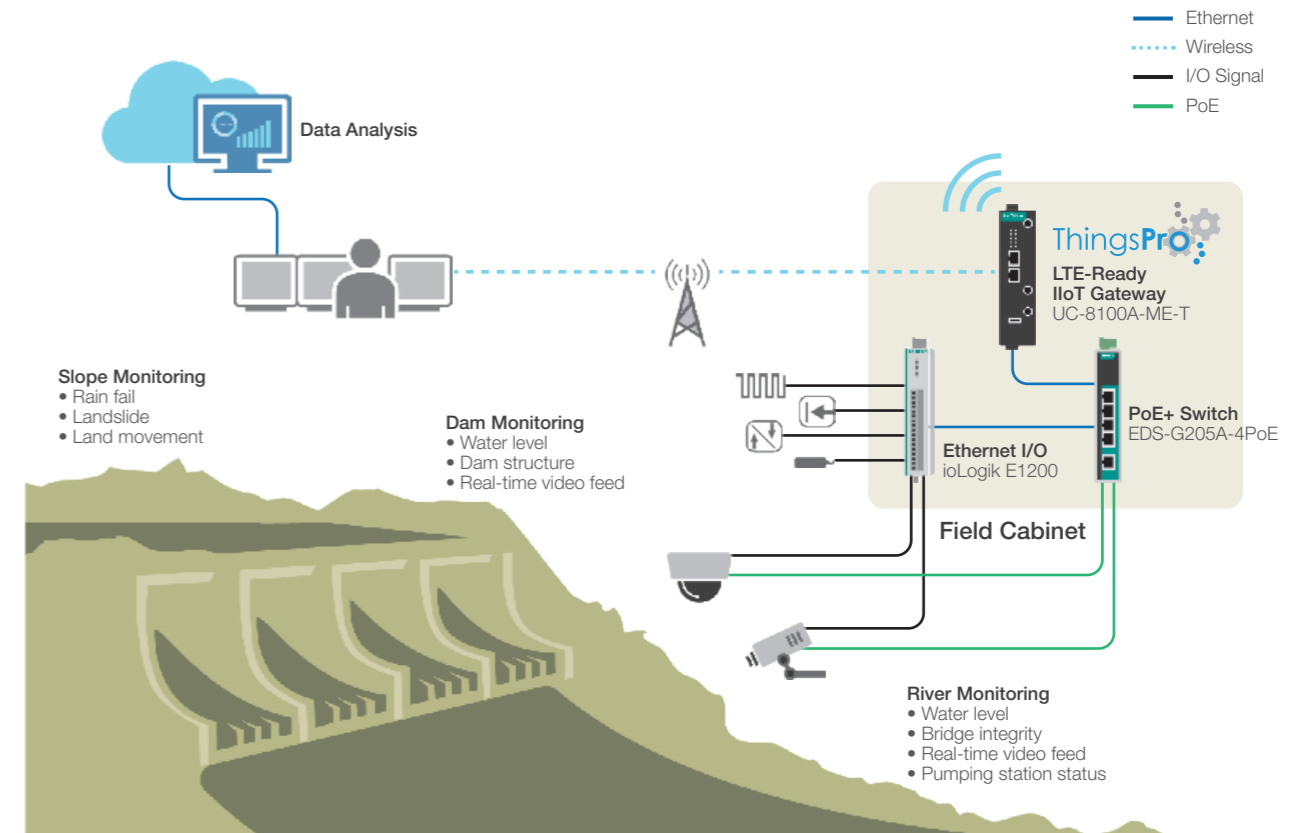

System Requirements

- Continuous data collection in outdoor environments
- Data should be delivered in IT formats that best support data-center and decision-making tools
- Track the equipment status using monitoring systems to reduced downtime

Why Moxa

- Smart data collection by ioLogik E1200 I/O devices that support multiple fieldbus protocols, peer-to-peer data transfer, and require far less wire runs
- ThingsPro Gateway software and UC-8100A computers make Modbus data readable for cloud platforms by performing Modbus-to-MQTT conversion
- UC-8100A computers can do stable 4G cellular routing for sensor data uplink and image streaming in a -40 to 70°C operating temperature range



Distributed Wellhead Monitoring in Onshore Oil and Gas Projects

As oil and gas fields are often spread over hundreds or even thousands of square miles and located in remote areas, many oil and gas companies are taking advantage of IIoT solutions to collect and process large volumes of data from the field for supporting their daily operation and decision making process.

System Architecture

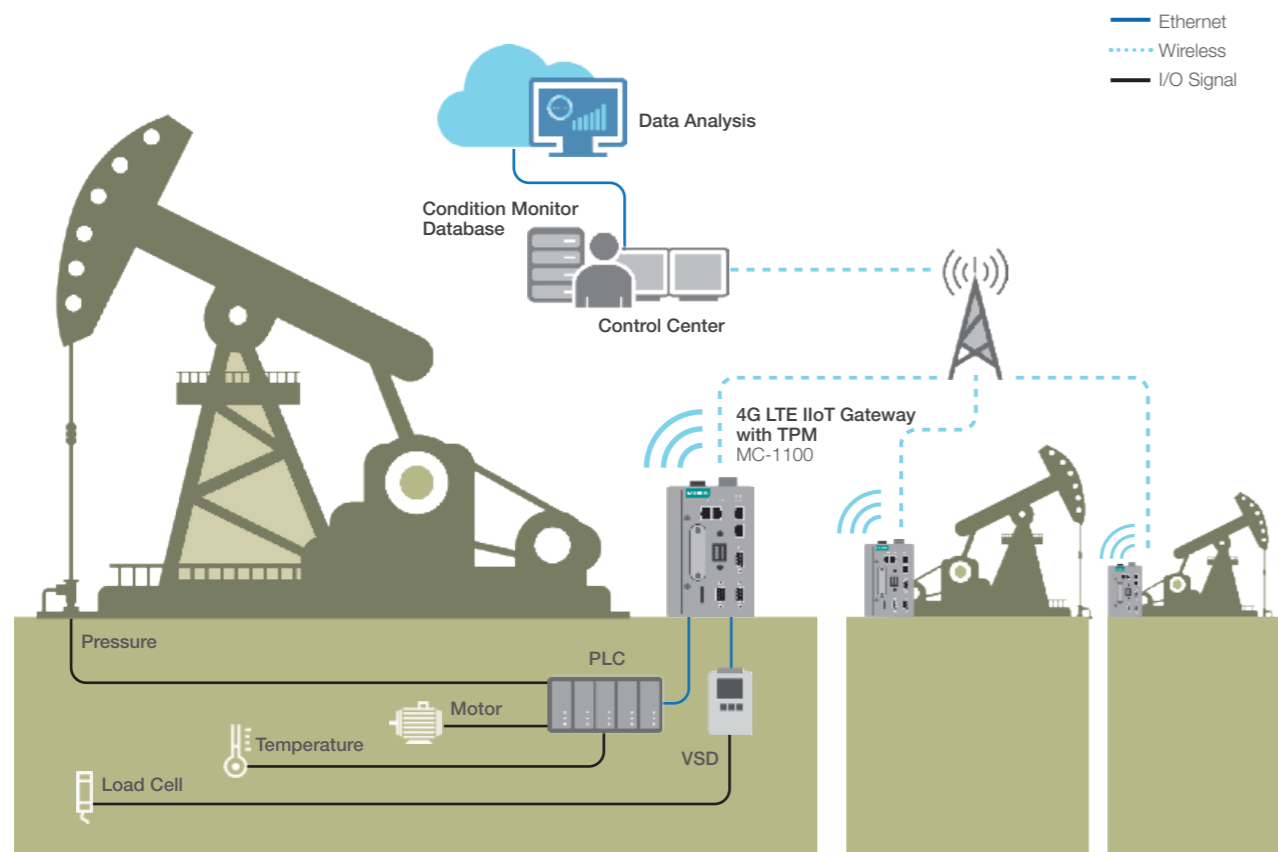

System Requirements

- Collect data from a wide array of field sensors and devices and transfer it to a cloud data center
- Energy-efficient data processing and transmission in hot and hazardous conditions
- Network reliability and security for data aggregation and integrity

Why Moxa

- The compact MC-1100 computers are equipped with an Intel Atom®-based processor and C1D2 and ATEX certifications to withstand hazardous conditions
- The MC-1100 computers facilitate Modbus-to-MQTT conversion and keep-alive LTE check to maintain stable data transfer to cloud services
- MC-1100 computers come with Ethernet, serial, and DI/DO interfaces for data connections
- Built-in Trusted Platform Module (TPM) for data integrity and security



Hybrid IIoT for Increased Productivity and Reduced Downtime

Manufacturers have found that using edge computers can help reduce the loading on cloud resources, simplify data processing, and improve overall device efficiency (OEE) using preventive maintenance. With powerful data analytics available as cloud services, companies only need to deploy Moxa's gateway computers and system sensors to measure and predict equipment conditions and thereby reduced downtime.

- **Wiring Savings:** System sensors will be directly connected to gateway computers for condition monitoring. Using this new wiring method, customers can discard some of the lines that were originally connected to SCADA
- **Reduce cloud spending :** Programmable data filtering reduces bandwidth and cloud resource consumption
- **Local intelligence:** Local data processing reduces latency and improves response time enabling real-time control and monitoring

System Architecture

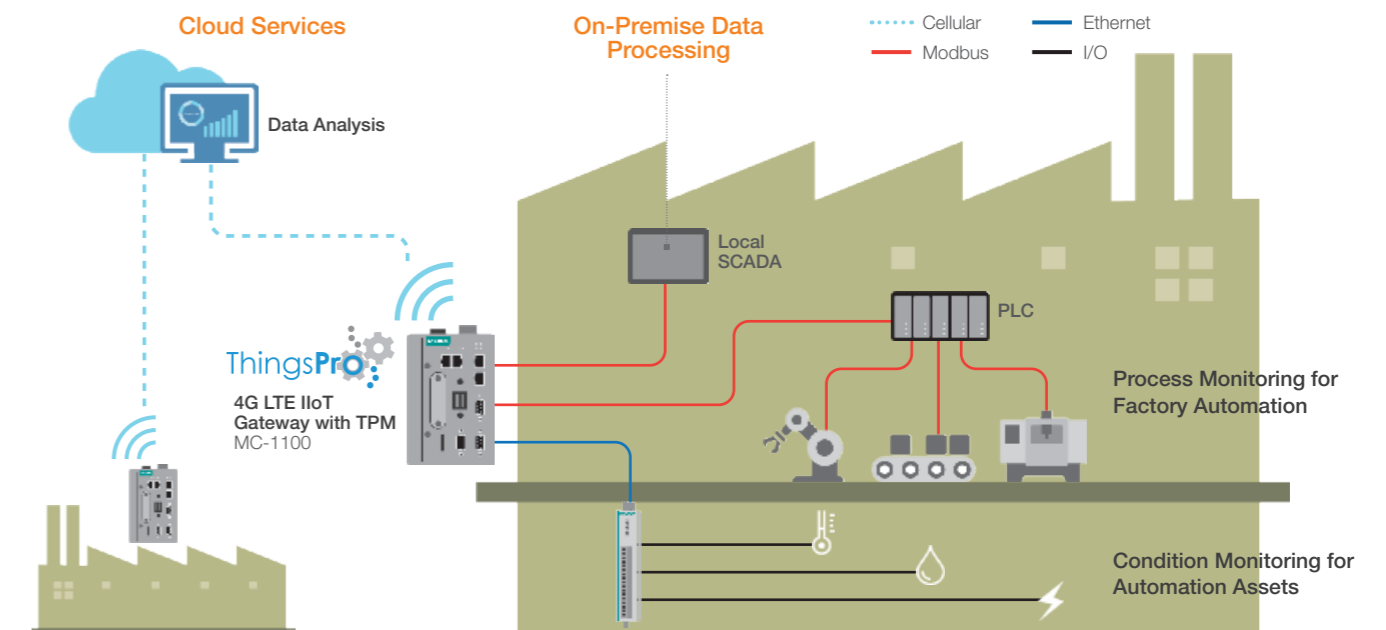

System Requirements

- Collect raw data from sensors and send to the local SCADA for operational purposes
- Collect system data of equipment status and transfer to public cloud platforms (e.g., Azure) for asset condition monitoring and analytics
- Quick and easy data filtering is required to save transmission and processing cost on cloud services

Why Moxa

- ThingsPro Gateway software on Moxa's MC-1100 computers provide configurable Modbus templates and RESTful APIs to simplify data collection and utilization
- Built-in SDK to develop programs for easy adoption of public cloud platforms
- Data-logger utility for Modbus-to-MQTT conversion
- Built-in Tag Selector to easily select and upload specific tags to cloud platforms

Ready-to-Run IIoT Solutions



ThingsPro® Gateway Software

- Ready-to-use data logger with Modbus templates
- Tag-based data acquisition with MQTT support
- RESTful APIs for developing custom applications
- Built-in clients for AWS, Azure, and Alibaba Cloud
- LTE keep-alive function to maintain stable data transfer

Eligible Devices

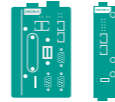

- Arm-based IIoT edge gateways: UC-2100, UC-3100, UC-5100, UC-8100, and UC-8100A-ME-T Series
- x86 IIoT edge gateways: MC-1100 Series

Industrial IoT Edge Gateways



Model Series	UC-2100	UC-3100	UC-5100	UC-8100A-ME-T	MC-1100
CPU	TI AM335x Cortex-A8	TI AM335x Cortex-A8	TI AM335x Cortex-A8	TI AM335x Cortex-A8	Intel® Atom E3845 / E3826
CPU speeds	Up to 1 GHz	1 GHz	1 GHz	1 GHz	1.91 GHz/ 1.46 GHz
RAM / Storage	Up to 512 MB / 8 GB	512 MB / 4 GB	512 MB / 8 GB	1 GB / 8 GB	Up to 8 GB / Optional
Storage Expansion	1 x micro SD	1 x SD	1 x SD	1 x SD	1 x CFast
USB 2.0 Ports	–	1	1	1	2
Serial Ports	Up to 2	Up to 2	4	2	Up to 4
CAN Ports	–	1	2	–	–
LAN Ports	Up to 2	2	2	2	Up to 4
DI/DO	–	–	4/4	–	4/4
Wireless Expansion	Wi-Fi/LTE	Built-in Wi-Fi/LTE	Wi-Fi/LTE	LTE	Wi-Fi, LTE, GPS
TPM	–	–	–	–	Optional
Dimensions	50 x 80 x 28 mm 57 x 80 x 30.8 mm 111 x 77 x 25.5 mm	128.5 x 89.1 x 26 mm 128.5 x 89.1 x 41 mm	136 x 100 x 57 mm	141.5 x 120 x 33 mm	132 x 122 x 68 mm 132 x 122 x 87 mm
Operating Temperature	-40 to 75°C	-30 to 70°C (with LTE)	-40 to 85°C -40 to 70°C (with LTE)		-40 to 70°C

Remote Ethernet I/O



	ioLogik E1210	ioLogik E1211	ioLogik E1212	ioLogik E1214	ioLogik E1213	ioLogik E1240	ioLogik E1241	ioLogik E1242	ioLogik E1260	ioLogik E1262	
DI / DO	16 / –	– / 16	8 / –	6 / –	4 / 4	– / –	– / –	4 / –	– / –	– / –	
AI / AO	– / –	– / –	– / –	– / –	– / –	8 / –	– / 4	4 / –	– / –	– / –	
Relays	–	–	–	6	–	–	–	–	–	–	
Configurable DIO	–	–	8	–	4	–	–	4	–	–	
Others										RTD*1 x 6	TC** x 8
RJ-45	RJ-45 x 2 for daisy chain connection										
Protocols	Modbus/TCP (slave), TCP/IP, UDP, DHCP, BOOTP, HTTP, SNMP										

* Resistance Temperature Detector

** Thermocouple

Industrial Ethernet Switches



Model Series	EDS-G512E-8PoE	EDS-510E	EDS-P506E-4PoE	EDS-408A	EDS-405A	SDS-3008	EDS-G205A-4PoE	EDS-205A/208A
Switch Type	Managed	Managed	Managed	Managed	Managed	Smart	Unmanaged	Unmanaged
No. of Ports	12 GE	3 GE + 7 FE	2 GE + 4 FE	8 FE	5 GE	8 FE	5 GE	5/8 FE
Gigabit RJ45 Ports	8	3	2	–	–	–	Up to 5	–
SFP Gigabit Ports	4	3 (Combo)	–	–	–	–	Up to 1	–
PoE/PoE+ Ports	8 PoE+	–	4 PoE+	–	–	–	4 PoE+	–
Industrial Protocols	EtherNet/IP, PROFINET, and Modbus/TCP (EDS-408A/405A for Ethernet/IP and Modbus/TCP only)						–	–
ISA/IEC 62443	Security features based on the IEC-62443 standard			–	–	–	–	–

MXstudio Industrial Network Management Suite



MXconfig Industrial Network Configuration Tool

- Mass-configuration function increases deployment efficiency and reduces setup time
- Link sequence detection eliminates manual configuration errors
- Security Wizard for easy set up and modification of device security parameters

MXview Industrial Network Management Software

- Automatic topology discovery and visualization with VLAN/IGMP grouping
- Security view for security status of devices
- Event playback for reviewable diagnostics
- Third-party devices supported by a MIB compiler and MIB browser
- OPC tags for easy SCADA/HMI management

N-Snap Industrial Network Snapshot Tool

- A standalone utility to take network snapshots for quick troubleshooting
- Automatically compares network and device data, and highlight the differences

MXview ToGo Mobile App for Network Monitoring

- Real-time notification for reduced downtime
- Quick network and device status checking
- Only one click for easy device search and mapping